

LISTEN.
THINK.
SOLVE.™



Error Proofing – Advanced Sensor Applications Lab (CPU20)

ALLEN-BRADLEY • ROCKWELL SOFTWARE **Rockwell
Automation**

Error Proofing – Advanced Sensor Applications: Hands-On Lab

Training Lab Manual

WELCOME TO ERROR PROOFING – ADVANCED SENSOR APPLICATIONS HANDS-ON LAB	9
ABOUT THIS HANDS-ON LAB	9
LAB MATERIALS	9
BEFORE YOU BEGIN	11
WELCOME TO 45MLD BACKGROUND SUPPRESSION LASER SENSOR HANDS-ON LAB	12
ABOUT THIS HANDS-ON LAB	12
LAB MATERIALS	12
SETUP THE 45MLD BACKGROUND SUPPRESSION LASER SENSOR	13
WELCOME TO 42CA 18MM CYLINDRICAL FIXED BACKGROUND SUPPRESSION HANDS-ON LAB	14
ABOUT THIS HANDS-ON LAB	14
LAB MATERIALS	14
42CA BACKGROUND SUPPRESSION OVERVIEW	15
42CA BACKGROUND SUPPRESSION APPLICATION	16
WELCOME TO THE 44B ADJUSTABLE BACKGROUND SUPPRESSION SENSOR HANDS-ON LAB	19
ABOUT THIS HANDS-ON LAB	19
LAB MATERIALS	19
44B ADJUSTABLE BACKGROUND SUPPRESSION SENSOR SETUP	20
HOW DOES BACKGROUND SUPPRESSION WORK?	22
WELCOME TO LONG RANGE BACKGROUND SUPPRESSION SENSORS (42BT AND 42BC) HANDS-ON LAB	25
ABOUT THIS HANDS-ON LAB	25
LAB MATERIALS	25
42BT LONG RANGE BACKGROUND SUPPRESSION	26

42BC LONG RANGE BACKGROUND SUPPRESSION	27
WELCOME TO 45BPD 300MM RANGE LASER DISTANCE MEASUREMENT HANDS-ON LAB	28
ABOUT THIS HANDS-ON LAB	28
LAB MATERIALS	28
BASIC 45BPD LASER MEASUREMENT SENSOR SETUP	29
45BPD TEACH PROCESS – ANALOG OUTPUT	31
ADDITIONAL FUNCTIONS FOR THE SENSOR	31
45BPD TEACH PROCESS – DISCRETE OUTPUT	32
WELCOME TO 45CPD LASER DISTANCE MEASUREMENT HANDS-ON LAB	33
ABOUT THIS HANDS-ON LAB	33
LAB MATERIALS	33
BASIC 45CPD LASER MEASUREMENT SENSOR SETUP	34
45CPD TEACH PROCESS – ANALOG OUTPUT	35
45CPD TEACH PROCESS – DISCRETE OUTPUTS – BACKGROUND SUPPRESSION APPLICATIONS	36
45CPD TEACH PROCESS – DISCRETE OUTPUTS – BACKGROUND AS A “REFLECTOR”	37
45CPD TEACH PROCESS – DISCRETE OUTPUTS – OTHER APPLICATIONS	38
WELCOME TO CLEAR OBJECT DETECTION HANDS-ON LAB	39
ABOUT THIS HANDS-ON LAB	39
LAB MATERIALS	39
CLEAR OBJECT DETECTION – STANDARD RETROREFLECTIVE VS. CLEARsIGHT	40
CLEAR OBJECT DETECTION – RIGHTsOUND (873E) ULTRASONIC	42
WELCOME TO COLORsIGHT™ 45CLR HANDS-ON LAB	43
ABOUT THIS HANDS-ON LAB	43
LAB MATERIALS	43

BASIC COLORSIGHT™ 45CLR SENSOR SETUP	44
TEACHING THE COLORSIGHT™ 45CLR SENSOR	46
USING THE COLOR SCAN FUNCTION OF THE COLORSIGHT™ 45CLR SENSOR	46
ADVANCED COLORSIGHT™ 45CLR SENSOR FUNCTIONS: TEACH MULTIPLE CHANNELS AND CHANGE TOLERANCE SETTINGS	47
ADVANCED COLORSIGHT™ 45CLR SENSOR FUNCTIONS: REMOTE TEACH	48

Welcome to Error Proofing – Advanced Sensor Applications Hands-On Lab

About This Hands-On Lab

Welcome to Error Proofing – Advanced Sensor Applications Hands-On Lab! This session provides you with the opportunity to explore many advanced Allen-Bradley photoelectric sensors and how they can be applied in Error Proofing applications. You will learn the setup and teach process of each sensor and experiment with a variety of targets. This lab will help you develop creative solutions to the most challenging sensor applications.

What You Will Accomplish In This Lab

As you complete the exercises in this hands-on session, you will:

- Learn how to setup many advanced Allen-Bradley Photoelectric Sensors
- Develop an understanding of the applications for those sensors

Who Should Complete This Lab

This hands-on lab is intended for individuals who:

- Need to solve the most challenging sensor applications
- Want to know more about Allen-Bradley sensor solutions

Lab Materials

For this Hands-On lab, we have provided you with the following materials that will allow you to complete the labs in this workbook. Each lab has an individual material list in that section.

Sensor Hardware

This hands-on lab uses the following hardware:

- 45MLD-8LEA1-P4 laser sensor
- 42CA-B2LPBC-D4 (or 42CM-B2LPBC-D4) 18mm Cylindrical Fixed BGS Sensor
- 44BSB-1JBA1-D4 Adjustable BGS Sensor
- 42BT-B2LBSL-F4
- 42BC-B1CRAN-T4 with 888D-M4AC1-0M3 (Micro QD receptacle)
- 45BPD-8LTB2-D5 laser measurement sensor with 300mm range
- 45CPD-8LTB1-D5 laser measurement sensor with 6m range
- 42KL-U2LB-A2 Standard Retroreflective MiniSight
- 42EF-C2KBA-F4 ClearSight RightSight
- 873EEDZZ0750F4 RightSound Ultrasonic sensor emitter
- 873ERD TT0750F4 RightSound Ultrasonic sensor receiver
- 45CLR-5JPC1-D8 ColorSight™ 45CLR sensor
- 45PVA Demo Case

Accessories

This hands-on lab uses the following software:

- 24VDC Power Supply for each lab station
- Base, stand, and clamp for each station
- 4-pin Pico QD Cordset – 889P-F4A-B2
- 5 X four conductor Micro QD Cordsets – 889D-F4AC-2
- 2 X five conductor Micro QD Cordsets – 889D-F5AC-2
- Eight conductor Micro QD Cordset – 889D-F8AB-2
- 2 x Multimeter with 4-20mA readout

Targets

This hands-on lab uses the following software:

- 3 small medicine bottles (45MLD Lab)
- 42CA BGS Lab Target (weld nut mounted on metal plate)
- Light, Dark, and Shiny card targets (44B Background Suppression Lab)
- Catalog or other thick book (42BT BGS Lab)
- Demo case cover or lid - 75-100mm / 3-4 inches thick (42BC BGS Lab)
- Lego blocks to simulate positioning, profiles, stacking, error proofing, and assembly (45BPD Laser Measurement Lab)
- Chair, lab partner, or other easily movable target (45CPD Laser Measurement Lab)
- Clear plastic bottle, clear glass bottle (Clear Object Detection Labs)
- Paint color cards – 3 similar colors and at least 1 very different color (ColorSight 45CLR Lab)

Before You Begin

The following labs assume the user has a basic knowledge of photoelectric sensing technologies and understanding of appropriate sensor wiring practice.

The Error Proofing – Advanced Photoelectric Sensor Applications Hands On Lab is a series of labs. Each lab is set up at a separate station. In order to complete these labs, you will move around the room to the various stations as you complete the labs. Please go to the stations in numeric order, moving back to Station 1 after you complete the last lab.

At the beginning of the session, please refer to the front of the room for a guide as to which labs are at which sessions. Fill in the below chart for a reference guide.

Station Number	Lab	Page	Complete?
	45MLD Laser Background Suppression Sensor	10	
	Fixed Background Suppression	12	
	Adjustable Background Suppression	17	
	Long Range Adjustable Background Suppression	23	
	45BPD Laser Measurement	27	
	45CPD Laser Measurement	32	
	Clear Object Detection	38	
	ColorSight 45CLR	42	
	45FVL as contrast	*	
	45PVA	*	
	45AST	*	
	Additional Labs	*	

* See lab station for lab manual

Welcome to 45MLD Background Suppression Laser Sensor Hands-On Lab

About This Hands-On Lab

Welcome to the 45MLD Background Suppression Laser Sensor Hands-On Lab! This session provides you with an opportunity to explore the functionality of the top performing discrete sensor in the Allen-Bradley portfolio. The following sections explain what you'll be doing in this lab session, and what you will need to do to complete the hands-on exercises.

What You Will Accomplish In This Lab

As you complete the exercises in this hands-on session, you will:

- Learn how to setup the 45MLD Background Suppression Laser Sensor

Who Should Complete This Lab

This hands-on lab is intended for individuals who:

- Sell sensors
- Specify and/or recommend sensors

Lab Materials

For this Hands-On lab, we have provided you with the following materials that will allow you to complete the labs in this workbook.

Hardware

This hands-on lab uses the following hardware:

- 45MLD-8LEA1-P4 laser sensor

Accessories and Targets

This hands-on lab uses the following accessories and targets:

- On-Machine Demo kit
- 889P-F4ABDM-1 (4 pin micro male to pico female patchcord)

-OR-

- 24VDC Power Supply
- 4 pin Pico QD Cordset – 889P-F4A-B2
- Base, stand, and clamp

-AND-

- 3 small medicine bottles

Setup the 45MLD Background Suppression Laser Sensor

Background suppression technology employs light triangulation to create a distinct focal plane that is the effective sensing area. Targets beyond this focal plane will not be detected. Unlike fixed-focus and sharp-cutoff sensors that achieve background suppression through their inability to see the background, true background suppression sensors actively sense both target and background

The objective of this experiment is to ensure that a cap is squarely and securely affixed to the top of a bottle. This error proofing application is common in high speed automated filling and capping operations

1. Position the sealed/capped bottle right side up on the work grid of the Demo case
2. Use the magnet base, a rod holder and a rod extension to position the 45MLD-8LEA1-P4 sensor approximately 3" above the capped bottle
3. Using the 889P-F4ABDM-1 (4 pin micro male to pico female), connect the 45MLD-8LEA1-P4 to port 6 on the 898D-P58PT-N12 8 port, DC Micro Distribution Box. Cable is not marked with tape.
4. **–OR–** Connect the 45MLD with supplied PICO cable. Connect the brown lead(+) to V+ and the blue lead(-) to V- GND on the Power Supply. Connect the black wire (output) to the Output Terminal (if available).
5. Place a cap on one bottle so that it appears skewed to the sensor
6. Turn the front lens (IRIS) on the 45MLD laser sensor to adjust the spot size to about ¼ inch beam size
7. Present a bottle with a skewed cap and adjust sensitivity so that the green LED is ON. Turn the adjustment screw on the back of the 45MLD sensor (to min. sensitivity) counterclockwise until you hit the stop or clutch on the potentiometer. It is a 30 turn adjustment so this may take many turns. Now turn the adjustment screw clockwise until you find the turn-on point for the sensor output. You can do this by visually monitoring the Target (green) LED on the sensor.
8. Target (green) LED on sensor should be on (corresponding output LED on the 898D-P58PT-N12 Distribution Box should also be on) when a skewed cap is presented to sensor
9. Replace the reject bottle with a properly capped one. Adjust the sensitivity counterclockwise until the target (green) LED is off.
10. Demonstrate that the sensor output is on (green) when a bad bottle is presented and off when a good bottle is presented.

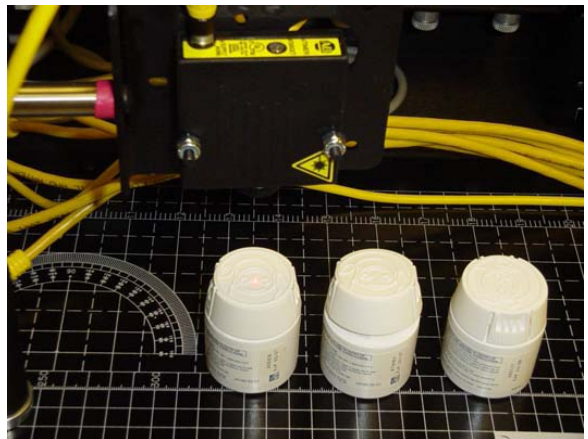
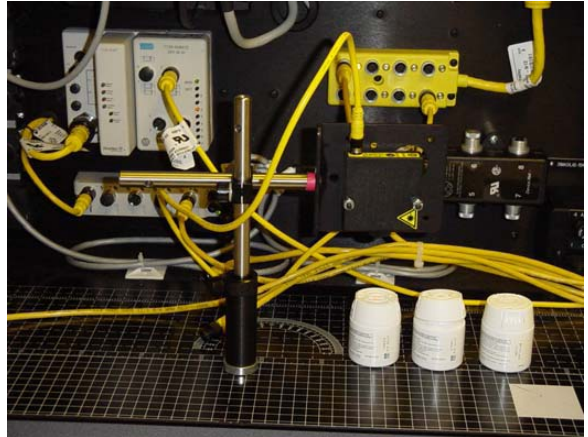

Welcome to 42CA 18mm Cylindrical Fixed Background Suppression Hands-On Lab

About This Hands-On Lab

Welcome to the 42CA 18mm Cylindrical Fixed Background Suppression Hands-On Lab! This session provides you with an opportunity to explore the basics of fixed range background suppression. The objective of this lab is to become familiar with the set up, operation, and functionality of the 42CA (or 42CM) 18mm Cylindrical Fixed Background Suppression photoelectric sensor. This lab will help the student identify a typical application where background suppression is required and the visible red LED light source simplifies implementation. The following sections explain what you'll be doing in this lab session, and what you will need to do to complete the hands-on exercises.

What You Will Accomplish In This Lab

As you complete the exercises in this hands-on session, you will:

- Learn the basics of fixed range background suppression
- Learn about a typical application
- Learn about the 42CA 18mm Cylindrical Fixed Background Suppression photoelectric sensor

Who Should Complete This Lab

This hands-on lab is intended for individuals who:

- Sell sensors
- Specify and/or recommend sensors

Lab Materials

For this Hands-On lab, we have provided you with the following materials that will allow you to complete the labs in this workbook.

Hardware

This hands-on lab uses the following hardware:

- 42CA-B2LPBC-D4 (or 42CM-B2LPBC-D4) 18mm Cylindrical Fixed Background Suppression Sensor

Accessories and Targets

This hands-on lab uses the following accessories and targets:

- 24VDC Power Supply
- 4-pin DC micro QD connector - 889D-F4AC-2
- Base, stand, and clamp
- Target (weld nut mounted on metal plate)

42CA Background Suppression Overview

Diffuse photoelectric sensors are desirable for use because only one unit needs to be mounted and wired. By comparison, transmitted beam requires the mounting and wiring of two units and retroreflective requires the mounting of a reflector. Diffuse sensing does, however, have one major drawback. As a result of using light reflected off a target to sense that target, diffuse sensors detect objects and different distances. For example, a white piece of paper will be detected much further away than a piece of black rubber. This factor can make applying diffuse sensors difficult. In order to minimize this effect, a mode of diffuse sensing called Background Suppression (BGS) was developed. Instead of having one internal light detector, a BGS sensor has two. Much the way having two eyes gives a person depth perception, the BGS sensor has “depth perception” and can determine if reflected light is coming from more than a certain distance away. When the sensor “sees” light that is more than a specific distance, it “suppresses” the output signal. Hence, the BGS sensor only changes the state of its output when it detects an object that is less than that specific distance. The 42CA and 42CM cylindrical sensor families include Background Suppression models that have a fixed sensing distance of either 2 or 4 inches (50 or 100mm). In this lab, we will use this suppression capability to detect a small object that is made out of the same material as the background.

Photoelectric sensors have traditionally been fitted with infrared (IR) LED light sources for the detection of industrial targets due to their reliability and performance. One drawback of IR is that it makes alignment of the sensor more difficult. For applications where tight alignment is necessary, having a photoelectric sensor with a visible red (VR) LED can be helpful. The 42CA and 42CM BGS models utilize VR light sources. This lab will demonstrate the ease of application when using a visible red LED.

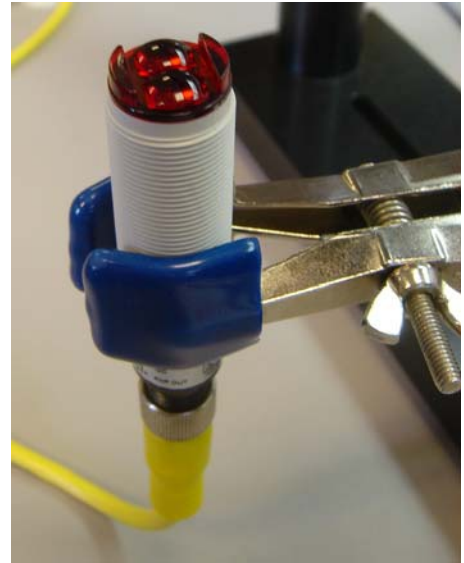

42CA Background Suppression Application

The objective of this lab is to demonstrate the ability of 42CA cylindrical BGS sensor to detect a weld nut mounted on a metal plate. This is only one of many possible applications where background suppression makes small parts detection possible and where the visible red beam simplifies setup.

1. Please start by setting up the stand, power supply, cordset, and photoelectric sensor. Securely fasten the 889D-F4AC-2 cordset to the photoelectric sensor and wire to the 24VDC power supply: +24VDC (brown) 0V (blue).
2. Connect the WHITE wire (pin 2) of the cordset to +24VDC. This changes the sensor from Dark Operate (DO) to Light Operate (LO). Target presence will make the output and the LED indicator turn ON.
3. Look at the lens of the sensor. When applying BGS sensors, it is important that the target moves perpendicular to the orientation of the two lenses. Make a mental note of the orientation of the lens.



Target should move perpendicular to lens orientation

Target moves left to right

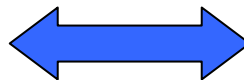

4. Securely fasten the photoelectric sensor to the one of the mounting plates so that the sensor is positioned approximately 2 inches above the table with its lens pointed down.
5. Look straight at the sensor. Spin the sensor inside the bracket until the outside ridges of the sensing face are to the left and right with the rounded lens in the middle.

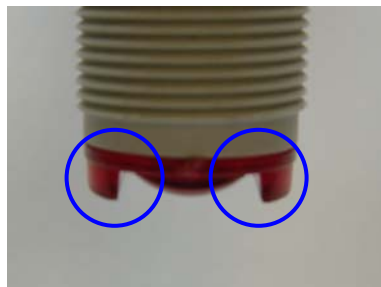
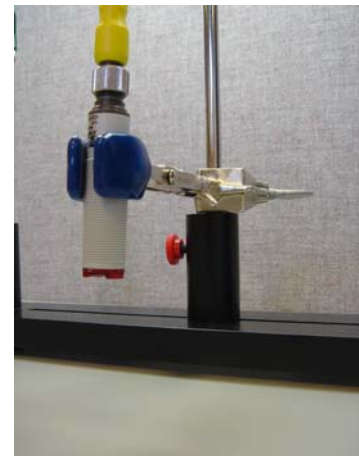

6. Turn the power supply ON. The sensor only has one indicator LED. The LED illuminates when the output is on.
7. Place the metal plate under the sensor. Position the plate so that the red spot is on the plate (not on the nut).



8. The output state was changed from the default Dark Operate (DO) to Light Operate (LO) in step two. This means the output (and the LED indicator) will be ON when the sensor detects a target closer than the suppression point. To position the sensor for the correct range, move the sensor down until the LED indicator turns ON (ie. the sensor detects the metal plate in range). Then move the sensor up until just after the LED turns OFF. The suppression point is just above the metal plate.

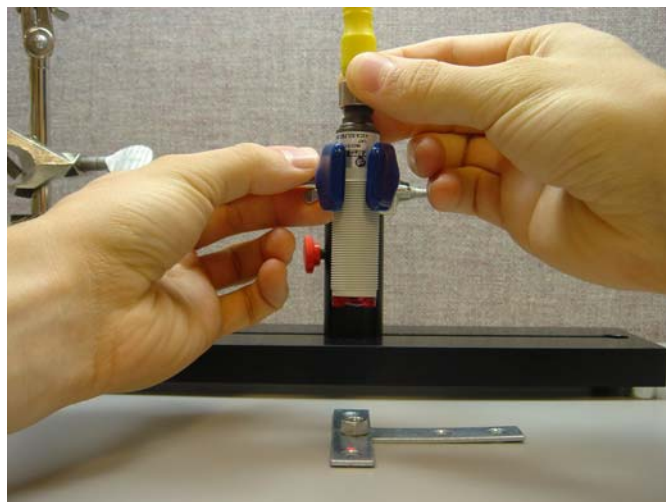

9. Move the target left to right under the sensor, passing the nut under the spot. Note that the sensor changes state for the nut but not for the metal plate.

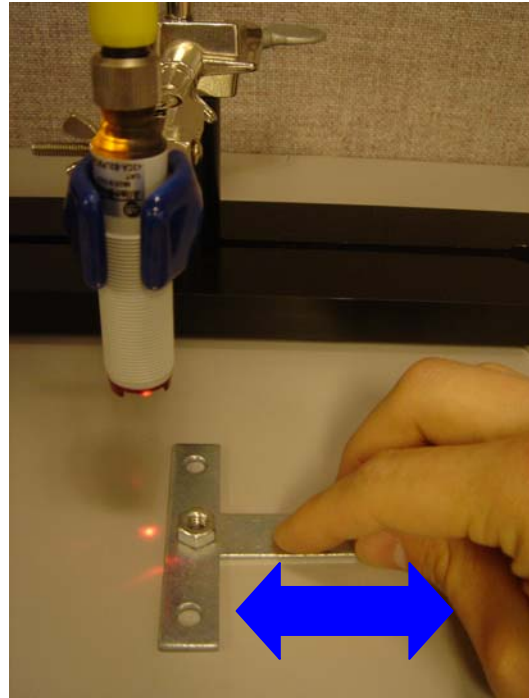

10. To demonstrate the importance of moving the target perpendicular to the lens axis, move the metal plate front to back, passing the red spot over the holes in the plate. Note that the sensor occasionally changes state when the spot passes over an edge or hole.

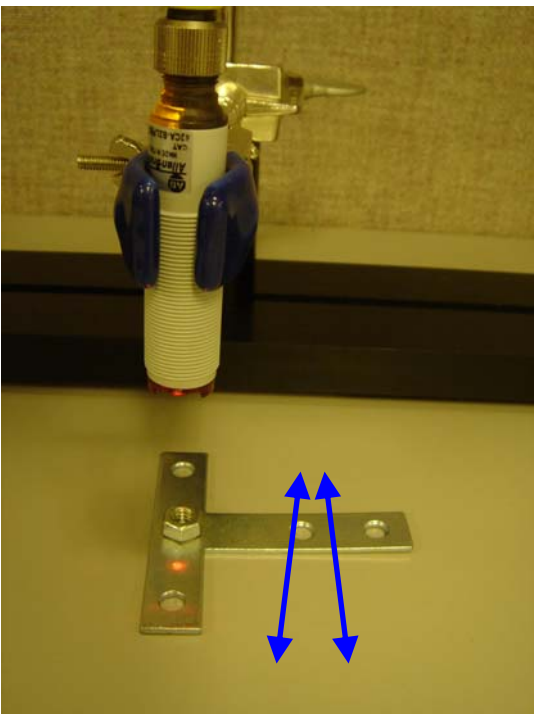

11. You have completed this portion of the lab.

Welcome to the 44B Adjustable Background Suppression Sensor Hands-On Lab

About This Hands-On Lab

Welcome to the 44B Adjustable Background Suppression Sensor Hands-On Lab! This session provides you with an opportunity to explore the functionality of the Allen-Bradley 44B sensor. You will learn about the setup and common applications of the sensor.

One common Error Proofing application is to confirm whether a product has been placed in a box. This can be challenging because sometimes the product and/or box changes size, color and/or material. In this example, the customer is an OEM designing a machine that places product into an open box. He wants a sensor to confirm that a product has been placed in a box. Several different types of product are to be handled by this machine and each of these products could have a different color and material associated with it. Additionally, different types and colors of boxes are used to package these products.

The solution for this OEM is to use a sensor that can detect objects at the same distance regardless of color. This sensor should also be able to ignore the box, even if it has a lighter color than the product. In this lab, you will see how this application is one of many that can be solved with the 44B Adjustable Background Suppression (ABGS) sensor. You will use the 44B ABGS sensor, along with light, dark and shiny pieces of cardboard to simulate the application scenario described above.

What You Will Accomplish In This Lab

As you complete the exercises in this hands-on session, you will:

- Learn how to setup the 44B Adjustable Background Suppression sensor

Who Should Complete This Lab

This hands-on lab is intended for individuals who:

- Sell, specify and/or recommend sensors

Lab Materials

For this Hands-On lab, we have provided you with the following materials that will allow you to complete the labs in this workbook.

Hardware

- 44BSB-1JBA1-D4 Adjustable BGS Sensor

Accessories and Targets

This hands-on lab uses the following accessories and targets:

- 24VDC Power Supply
- 4 conductor Micro QD Cordset – 889D-F4AC-2
- Base, stand, and clamp
- Light, Dark, and Shiny card targets

44B Adjustable Background Suppression Sensor Setup

In this section of the lab, you will set up the 44B sensor.

11. Connect the cordset to the sensor.
12. Connect the Brown wire of the cordset to V+ (24VDC) on the power supply.
13. Connect the Blue wire of the cordset to V- (usually GND) on the power supply.
14. Connect the Black wire of the cordset to the output terminal of the power supply (if available)
15. Turn on the power supply.
16. Familiarize yourself with the meaning of the indicator LEDs

LED Color	State	Status
Green	OFF	Sensor not powered
	ON	Sensor powered
	Flashing	Unstable margin (0.5X to 2X margin), SCP active
Orange	OFF	Output not activated
	ON	Output activated

17. Mount the sensor pointed at a range of 100mm / 4 inches. Be sure that the adjustment knob and LED indicators are facing you.
18. Place the dark target on the table under the sensor.
19. The dark background represents a dark box in our error proofing example. We wish to be able to detect objects that are placed inside the box regardless of their color. These objects may also be relatively flat, so we want a sensor that is able to detect objects that are within a certain sensing range but not detect any objects that fall beyond that (the interior of the box for example).
20. Rotate the cutoff point knob counterclockwise until you hear an audible “click”, to set the sensing distance to its minimum value.
NOTE: A six turn cutoff point adjustment knob is used on the 44BSB sensor. The knob makes an audible “click” at the end of its range.
21. Rotate the cutoff point knob clockwise until the Orange status LED turns ON
NOTE: The orange output LED will turn OFF and then back ON even if it is already ON with the adjustment knob set at the minimum setting.
22. Slowly rotate the adjustment knob counterclockwise until the orange status LED just turns OFF and the green margin indicator is not flashing.
23. Here we are using the precision offered by the 6 turn knob to precisely set the suppression point of the 44B sensor so that it does not see the box (represented by the black card).

24. Slide a light colored object (e.g. a business card) just above the background surface and observe. Does the sensor detect the card? How close to the background can you position the card? The object represents the product that we are trying to detect in our application example. The distance between the target and background corresponds to the minimum product profile height.
25. Slide a dark card or object along the dark background and observe. Does the sensor detect the card? How far in front of the background surface do you need to be to detect the dark target? The dark target represents a dark colored product in our application example.

NOTE: You can use the dark side of another background target card as the target to be detected if you have one.

26. Repeat the previous step using a shiny reflective target (foil, metal sheet, mirror, etc). Does the sensor detect the target? How far in front of the background surface do you need to be to detect the shiny target?
27. Remove the dark background card. Replace with a light background card.
28. Confirm that the output indicator is off – the color of the background does not affect the cutoff point.
29. Slide a second light card above the light “background” card. Confirm that the sensor turns on.
30. Slide a dark target above the light “background” card. Confirm that the sensor turns on. Note that the sensor “sees” a dark target immediately in front of a light background.
31. Repeat the setup using a shiny background. What do you observe regarding the distance between targets and background for the different types of target? Can the sensor detect dark, shiny and/or bright targets when you have a shiny background?
32. Did you observe any differences in the ability of the sensor to detect the different colored targets? Did the color of the background have any affect on the performance?
33. You should have observed that the BGS sensor was able to detect both light and dark objects are approximately the same range when using either a light or dark background.
34. Shiny targets and backgrounds sometimes present a challenge. This can be compensated for by angling the sensor.

TIP: Have you ever wondered how you could see the light spot generated by an infrared sensor? One very common consumer electronics product solves this problem – the inexpensive digital camera included on many cell phones. Unlike more expensive digital cameras, phone-cameras rarely have infrared filters. This allows the imaging chip to see infrared light, which it will then show on its display. It generally shows up as a white or bluish color.

SHORT DEMO: Put a camera-phone into camera mode. Point the camera at the emitter element of a 44B (or any infrared) sensor. Note the bright white or bluish spot that shows up. Now point the sensor at a solid color target. Point the camera at the approximate point where you would expect the light spot to show up. Can you see the spot? You may need to shield other light sources away from the target or turn off the lights in the room. This is both a good way to confirm that emitter LED is working and also to confirm exactly what the sensor is pointing at and how big the light spot is. Unless the room is dark, you’ll probably only be able to pick up the spot within a few inches.

How does Background Suppression Work?

In this section of the lab, you will learn how background suppression works.

Many of today's applications require the reliable detection of objects that fall close to a surface which must be ignored. Standard diffuse sensors will often trigger on these backgrounds, especially when they are of a light or highly reflective surface. In some cases it is not possible to use a retroreflective sense mode and reflector so it becomes desirable to use a photoelectric sensor with either a background or foreground suppression sense technology.

The Series 44B photoelectric sensor is available in two sense modes designed to minimize these background reflections. Both use a light source and dual receiver optics system with mechanically adjustable control for maximum cutoff point precision. Using the six turn adjustment knob on the top of the sensor, a desired cutoff point can be set to meet the specific application requirement.

The difference between the two 44B sense modes lies in their operation. Although both sense modes will actively "see" the background condition using a second internal receiver, the background suppression (BGS) sense mode will output when it "sees" reflected light from the target. In contrast, the foreground suppression (FGS) sense mode will use the background as a "reflector" and output when sensed area is blocked by the target. A BGS is typically operated in Light Operate mode whereas a FGS sensor is typically operated in Dark Operate mode.

The illustration below demonstrates how the suppression point for both sensors is set by turning an adjustment knob, which mechanically adjusts the angle of a mirror element. The angle of this mirror affects whether reflected light is detected by the "far" receiver (R1 below) or the "near" receiver (R2 below).

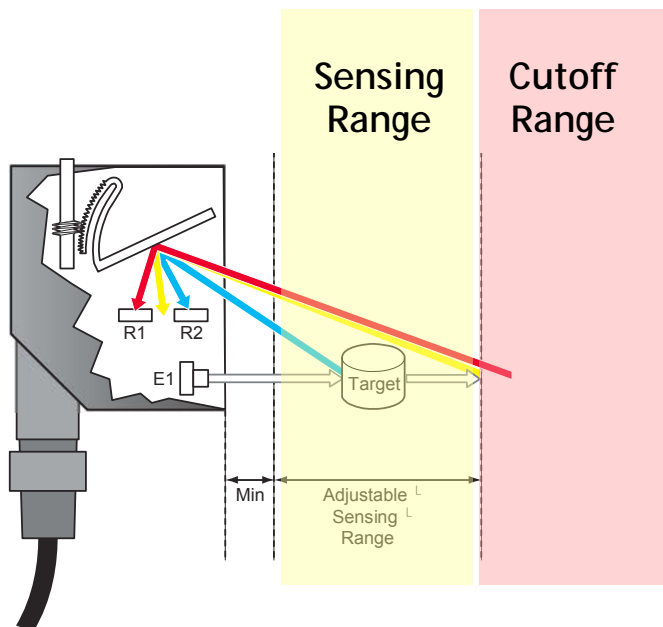

For added installation and troubleshooting assistance, both sense modes contain a green LED status indicator to warn the user of an unstable application condition –i.e. dirty lens, low contrast.

This indicator will remain steady ON during normal operation, but flash to indicate a change in the application environment or a low margin..

Application Notes:

Due to the detection method used by both background and foreground suppression sensors, it is important that the sensor be mounted in such a way as to ensure that the target passes in an orientation perpendicular to the sensors lenses. It should also be noted that the gap between the cutoff point and the target will vary with the shape and reflectivity of the target.

In general, the foreground suppression sense mode should be used when looking at dark, irregularly shaped or shiny targets on a highly reflective background. BGS mode is well suited for either light or dark targets on light or dark backgrounds. Shiny targets and/or backgrounds present a challenge for both sensing modes. FGS sensors are recommended in applications that involve shiny mirror like surfaces. However, such an environment may require the sensor to be mounted at an angle to the shiny surface for correct operation.

Top illustration shows a standard diffuse photoelectric sensor at top and background suppression sensor at bottom.

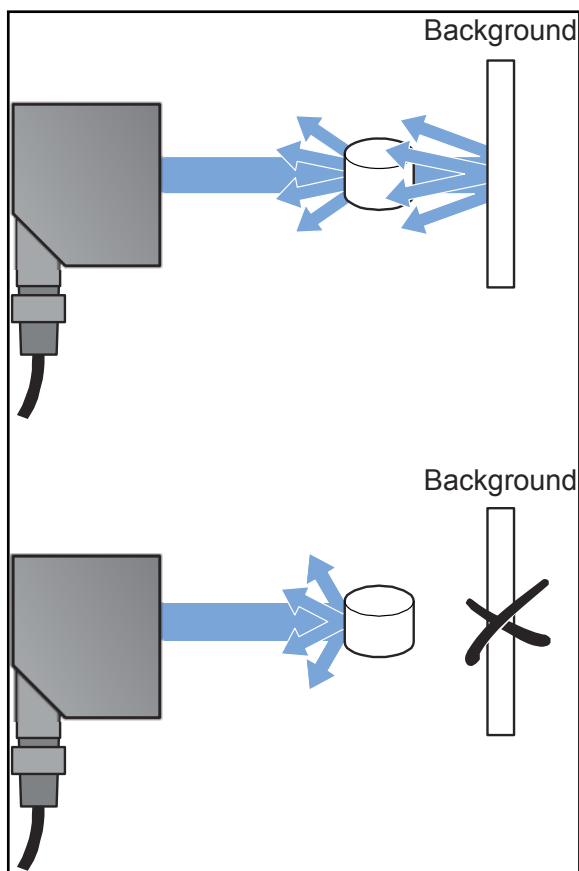

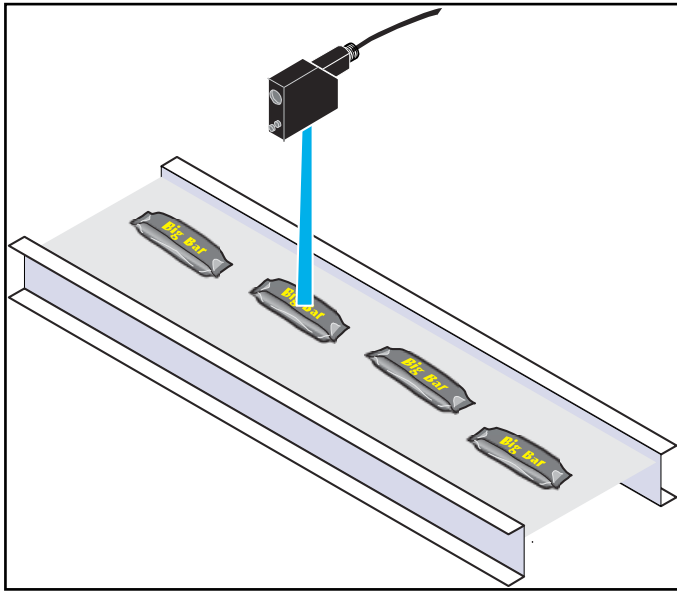

Foreground Suppression Application Example: Detecting Dark or Shiny Candy Bar Wrappings on Reflective Background

Welcome to Long Range Background Suppression Sensors (42BT and 42BC) Hands-On Lab

About This Hands-On Lab

Welcome to the Long Range Background Suppression sensors Hands-On Lab! This session provides you with an opportunity to explore the functionality and application of the Allen-Bradley 42BT and 42BC sensors. These products have sensing ranges of up to 2m (6.6 ft). The following sections explain what you'll be doing in this lab session, and what you will need to do to complete the hands-on exercises.

What You Will Accomplish In This Lab

As you complete the exercises in this hands-on session, you will:

- Learn how to setup the 42BT and 42BC Long Range Background Suppression Sensors

Who Should Complete This Lab

This hands-on lab is intended for individuals who:

- Sell sensors
- Specify and/or recommend sensors

Lab Materials

For this Hands-On lab, we have provided you with the following materials that will allow you to complete the labs in this workbook.

Hardware

This hands-on lab uses the following hardware:

- 42BT-B2LBSL-F4
- 42BC-B1CRAN-T4 with 888D-M4AC1-0M3 (Micro QD receptacle)

Accessories and Targets

This hands-on lab uses the following accessories and targets:

- 24VDC Power Supply
- 4 conductor Micro QD Cordset – 889D-F4AC-2
- Base, stand, and clamp
- Catalog or other thick book
- Demo case cover or lid (75-100mm / 3-4 inches thick)

42BT Long Range Background Suppression

In this section of the lab, you will set up the 42BT Background Suppression Sensor. You will use the sensor to detect the catalog.

1. Connect the 42BT-B2LBSL-F4 with supplied Micro cordset. Connect the brown lead (+) to V+ on the 24VDC power supply and the blue lead (-) to V- (which usually connected to GND).
2. The 42BT PNP and NPN outputs are inverted from the standard wiring – Black is NPN and White is PNP. Connect the white wire (PNP output) to the output indicator (if available).
3. Turn the 24VDC power supply on.
4. Set up the 42BT facing the wall. The 42BT sensor we are using for this lab has a sensing range of 0.2 m – 1m (0.66-3.3ft). Place the sensor approximately 1.5 – 2 feet away from the wall. When the sensor is powered up you should see a visible red dot on the wall.
5. Make sure the LO/DO switch on the top of the sensor is set to LO.
6. Turn the adjustment for near/far until both the green and red light turn on.
7. The green light is the margin indicator and the red light is the indicator for the output of the sensor. When both lights turn on this indicates that the sensor has detected the wall.
8. Turn the near/far adjustment counterclockwise (ccw) slowly until both lights turn off.
9. Place the sensor catalog against the wall. If the sensor is set right both lights will turn on, indicating that the catalog has been detected.



42BC Long Range Background Suppression

In this section of the lab, you will set up the 42BC Background Suppression Sensor. You will use the sensor to detect the demo case lid.

1. The 42BC has a screw terminal interface for electrical connection. For the purpose of this lab, a standard Micro QD receptacle (888D-M4AC1-0M3) has been wired into the unit for ease of use. The receptacle is wired in the following way:

Terminal	Connection	QD Pin
1	24VDC – V+	1
2	V- (typically GND)	3
3	Relay connection - short to QD pin 1 (V+)	N.C.
4	Relay output	4



2. This QD is wired in the standard fashion, so pin 4 / black wire of the cordset is the output. Disconnect the white wire from the previous lab and connect the black wire to the output terminal (if available).
3. Set up the 42BC on a table facing the wall. The sensor that we are using in this demo is a 24-120V AC/DC unit with a sensing range of 30 mm – 2 m (1.2 in – 6.6 ft). Set the sensor approximately 4-5 feet away from the wall. There will be no visible red dot with this sensor, as it uses an infrared LED.
4. Make sure the LO/DO switch is set to LO.
5. Turn the near/far adjustment until both the green and red lights are on (Green light is the Margin light and the Red light is the output light). The sensor is now detecting the wall.
6. Turn the near/far sensor ccw slowly until both lights turn off.
7. Place the lid of the demo unit against the wall. Both lights will turn on when the lid is detected.

TIP: One very common consumer electronics product allows you to see the light spot generated by an infrared sensor – the inexpensive digital camera included on many cell phones. Unlike more expensive digital cameras, phone-cameras rarely have infrared filters. This allows the imaging chip to see infrared light, which it will then show on its display.

SHORT DEMO: Put a camera-phone into camera mode. Point the camera at the emitter element of a 44B (or any infrared) sensor. Note the bright white or bluish spot that shows up. Now point the sensor at a solid color target. Point the camera at the approximate point where you would expect the light spot to show up. You may need to shield other light sources away from the target or turn off the lights in the room. This is both a good way to confirm that emitter LED is working and also to confirm exactly what the sensor is pointing at and how big the light spot is. Unless the room is dark, you'll probably only be able to pick up the spot within a few inches.

Welcome to 45BPD 300mm Range Laser Distance Measurement Hands-On Lab

About This Hands-On Lab

Welcome to the 45BPD 300mm Range Laser Distance Measurement Hands-On Lab! This session provides you with an opportunity to explore the functionality of the analog distance measurement laser sensor. The objective of this lab is to provide familiarity with the set-up and functionality of the 45BPD sensor. The following sections explain what you'll be doing in this lab session, and what you will need to do to complete the hands-on exercises.

What You Will Accomplish In This Lab

As you complete the exercises in this hands-on session, you will:

- Learn how to teach the analog output of the 45BPD
- Learn about different application setups for the discrete output of the 45BPD

Who Should Complete This Lab

This hands-on lab is intended for individuals who:

- Sell sensors
- Specify and/or recommend sensors

Lab Materials

For this Hands-On lab, we have provided you with the following materials that will allow you to complete the labs in this workbook.

Hardware

This hands-on lab uses the following hardware:

- 45BPD-8LTB2-D5 laser measurement sensor with 300mm range

Accessories and Targets

This hands-on lab uses the following accessories and targets:

- 24VDC Power Supply
- 5 conductor Micro Cordset – 889D-F5AC-2
- Multimeter with 4-20mA readout
- Base, stand, and clamp
- Lego blocks to simulate positioning, profiles, stacking, error proofing, and assembly.

Basic 45BPD Laser Measurement Sensor Setup

In this section of the lab, you will set up the ColorSight™ 45CLR sensor.

1. Mount the 45BPD-8LTB2-D5 sensor onto the clamp bracket which is attached to the lab stand.
2. Verify that the sensor is mounted approximately 8-9" above the table and is facing down as shown.
3. Verify that the cordset wiring is connected to the 24V DC power supply: Brown (+) and Blue (-)
4. Verify that the Red multimeter test lead (mA) is connected to the 4-20mA analog output of the sensor (White cordset wire).
5. Verify that the Black multimeter test lead (COM) is connected to the (-) return on the power supply (Blue wire for the cordset is also connected here).
6. Verify that the switch output (Black cordset wire) and control input (Grey cordset wire) are not connected for this part of the lab. See wiring diagram below.

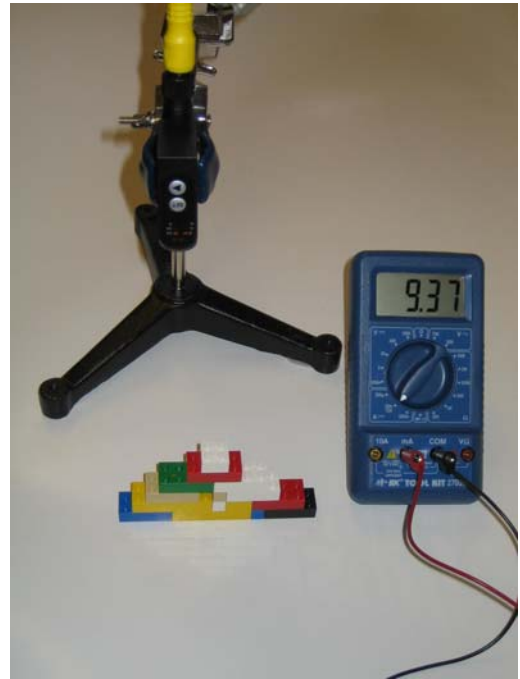

7. Verify that the Red multi-meter lead is connected to the mA terminal for the meter and turn on the multimeter and select the 20mA range.
8. Turn on the power supply
9. Familiarize yourself with the sensor's power and indicating LEDs in the operating mode and also as you proceed through the teach-in process. The 45BPD-8LTB2-D5 has several LED indicators to indicate output status, margin, target within range and settings. See below for description

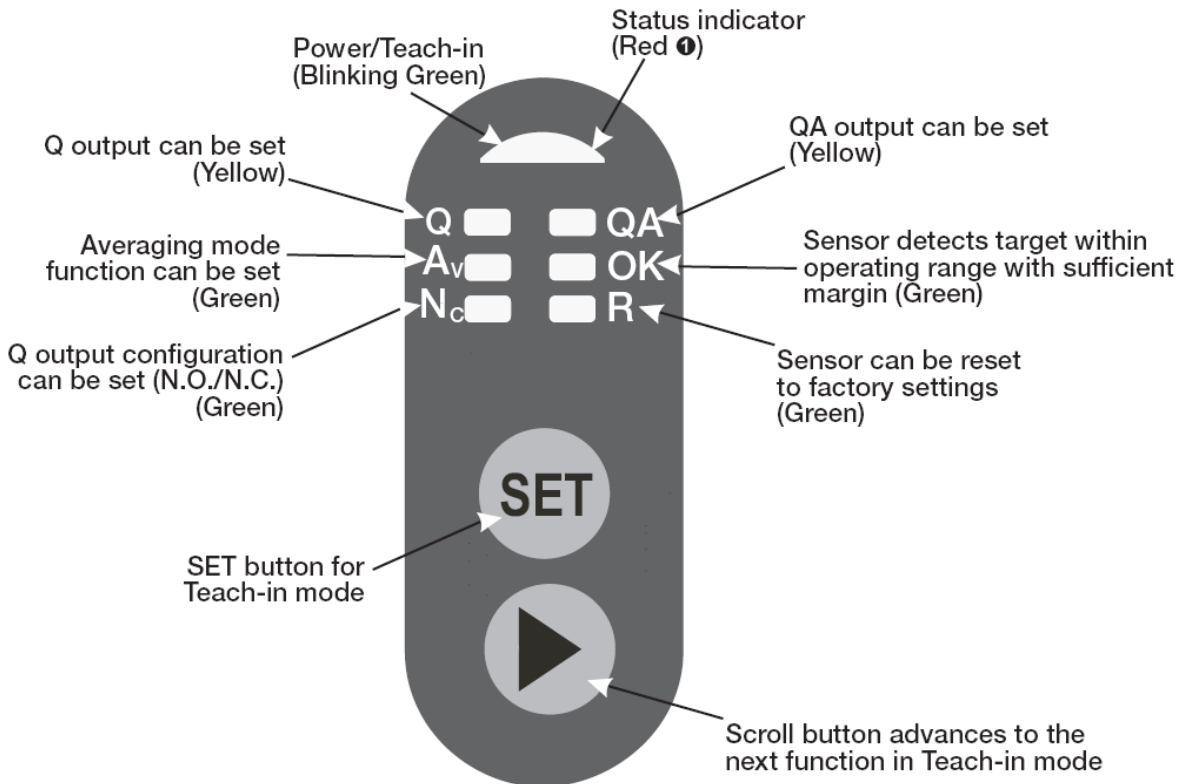
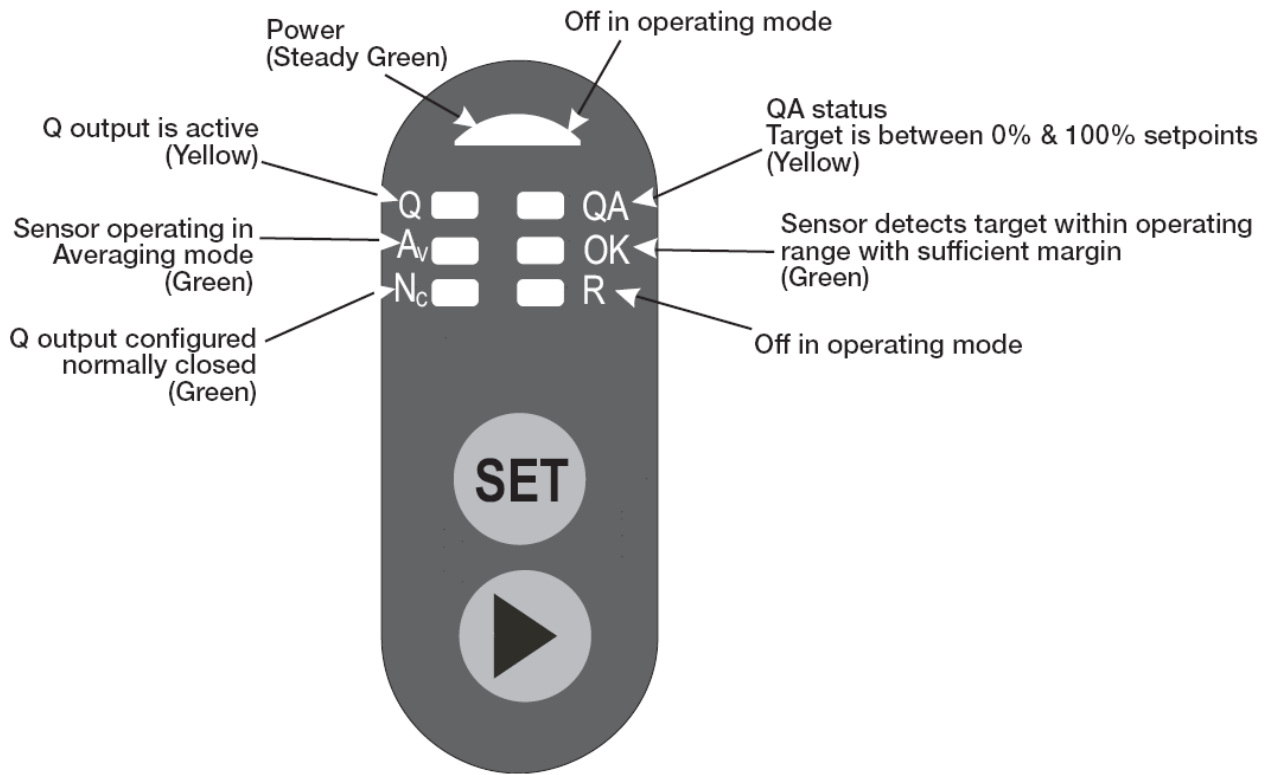

45BPD Teach Process – Analog Output

In this section of the lab, you will learn how to teach the analog output of the 45CPD sensor.

1. Press SET and ► simultaneously for 3 seconds to begin the Teach-In process. (green LED Power/Teach-In will begin blinking)
2. Press ► to scroll to the desired function indicated by the LEDs.

NOTE: To skip over a function and not change a setting, press the ► button to advance to the desired function. After the last function is reached the menu is started again from the first function.

3. Select the “R” function and then press SET to Reset the sensor to the factory settings.
4. Select the QA function which is the 4-20mA analog output.
5. Place the target at the 0% (4mA) position (e.g. remove the target) and press SET (red Status indicator LED will begin to blink). Here we will set the table as the 0% (4mA) position.
6. Place the target at the 100% (20mA) position (e.g. laser pointing at the top Lego) and press SET (the red Status indicator LED will turn off after this). Here we will set the top of the target profile as the 100% (20mA) position. (We are using LEGO blocks for this lab to show the concept for stacking, profiling, assembly, positioning.)
7. Press SET and ► simultaneously for 1 second to exit the Teach-In process and begin sensor operation (green LED stops blinking).

NOTE: The slope for the analog output can be inverted by teaching the 0% setpoint as the top of the profile and the 100% point as the table.

8. Place the target (LEGO blocks) in front of the sensor and monitor the reading of the multimeter as you move or change the target to simulate: stacking, profiling, error proofing, positioning, and assembly

Additional functions for the sensor

In this section of the lab, you will learn how to use the laser inhibit and teach button lock functions. You will also learn about some of the other capabilities of the sensor.

1. Connect the Control input (Grey wire) to +24V DC to disable the laser and hold the last value. Verify that the laser turns off and that the reading does not change on the multimeter as you move the target.
2. Connect the control input to the power supply negative (0V DC). Press the buttons on the sensor to verify that they are “locked-out.”

NOTE: The sensor can be set for averaging mode (last 100 measured values)

45BPD Teach Process – Discrete Output

In this section of the lab, you will learn how to teach the discrete output of the 45BPD sensor.

1. Press SET and ► simultaneously for 3 seconds to begin the Teach-In process. (green LED Power/Teach-In will begin blinking)
2. Note that the yellow Q discrete output indicator is on, indicating that the sensor is ready to teach the discrete output.
3. Position the target at the setpoint.
4. Press the SET button and the status indicator LED will begin to blink. This sets the switchpoint.
5. Press SET and ► simultaneously for 1 second to exit the Teach mode and begin sensor operation.
6. Confirm that the output changes state as the target is moved in and out of range.
7. To invert the output, put the sensor into teach mode - Press SET and ► simultaneously for 3 seconds. (green LED Power/Teach-In will begin blinking)
8. Press ► button 3 times until the NC green LED indicator turns on.
9. Press the SET button. The red LED indicator will turn on or off, depending on the current state.
10. Press SET and ► simultaneously for 1 second to exit the Teach mode and begin sensor operation.
11. Confirm that the output state is inverted.
12. Please turn off the power supply and multimeter after lab is completed.

NOTE: The discrete output (Q) can be set for either a switch point or a switching window.

Welcome to 45CPD Laser Distance Measurement Hands-On Lab

About This Hands-On Lab

Welcome to the 45CPD Laser Distance Measurement Hands-On Lab! This session provides you with an opportunity to explore the functionality of the 6m range analog distance measurement laser sensor. The objective of this lab is to provide familiarity with the set-up and functionality of the 45CPD sensor. The following sections explain what you'll be doing in this lab session, and what you will need to do to complete the hands-on exercises.

What You Will Accomplish In This Lab

As you complete the exercises in this hands-on session, you will:

- Learn how to teach the analog output of the 45CPD
- Learn about different application setups for the discrete output of the 45CPD

Who Should Complete This Lab

This hands-on lab is intended for individuals who:

- Sell sensors
- Specify and/or recommend sensors

Lab Materials

For this Hands-On lab, we have provided you with the following materials that will allow you to complete the labs in this workbook.

Hardware

This hands-on lab uses the following hardware:

- 45CPD-8LTB1-D5 laser measurement sensor

Accessories and Targets

This hands-on lab uses the following accessories and targets:

- 24VDC Power Supply
- 5 conductor Micro Cordset – 889D-F5AC-2
- Multimeter with 4-20mA readout
- Chair, lab partner, or other easily movable target

Basic 45CPD Laser Measurement Sensor Setup

In this section of the lab, you will set up the 45CPD sensor.

1. Place the sensor on table, pointing towards a wall 2 to 6 m (6 to 20 ft) away
2. Verify that the cordset wiring is connected to the 24V DC power supply: Brown (+) and Blue (-)
3. Verify that the primary discrete sensor output (Black cordset wire) is connected to the output terminal of the power supply (if available).

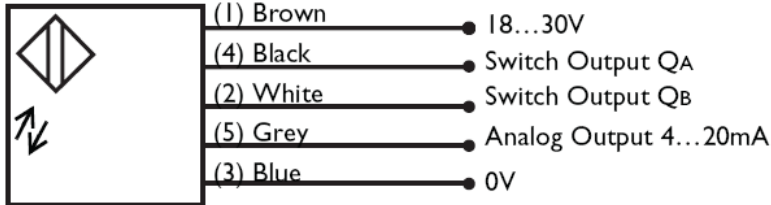

4. Verify that the Red multimeter test lead (mA) is connected to the 4-20mA analog output of the sensor (Gray cordset wire).
5. Verify that the Black multimeter test lead (COM) is connected to the (-) return on the power supply (Blue wire for the cordset is also connected here).
6. Verify that the Red multimeter lead is connected to the mA terminal for the meter and turn on the multimeter and select the 20mA range.
7. Turn on the power supply
8. Familiarize yourself with the sensor's power and indicating LEDs in the operating mode and also as you proceed through the teach-in process. The 45CPD has several LED indicators to indicate output status and settings. See below for description.

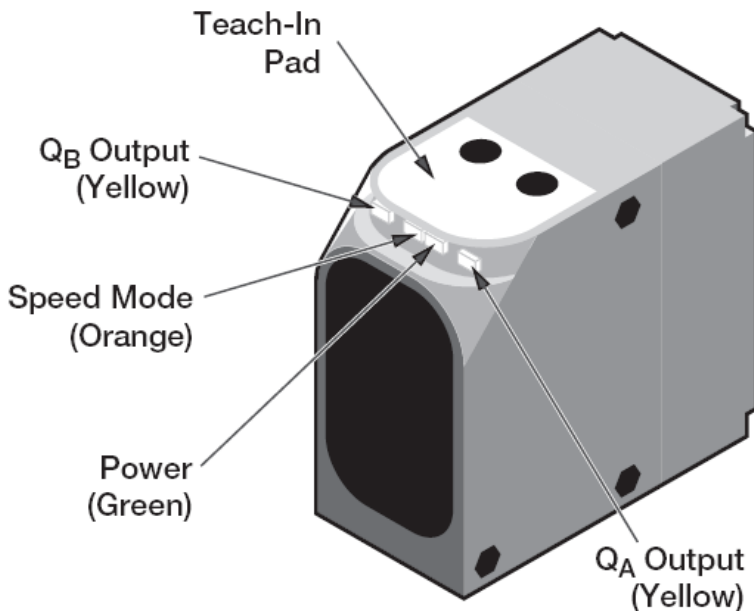

45CPD Teach Process – Analog Output

In this section of the lab, you will learn how to teach the analog output of the 45CPD sensor.

1. Check that the sensor is in Run mode – no red teach indicator LEDs, no red laser spot. (If a red teach indicator LED is on or if you see a visible red laser spot, the sensor is in teach mode. Press ► and SET simultaneously for approximately 1 second to put the sensor in Run mode.)
2. Press ► for 15 seconds (while in run mode) to reset factory defaults
3. Press SET for 3 seconds to put the sensor in Teach mode. The red AS1 LED will turn on and the laser source will change to visible red, creating a red spot on the target.
4. Place the target (chair, lab partner, other movable object...) at the “close” position (0.2 to 3m / 8 inches to 12 feet). Be sure the red laser spot is on the target.
5. Set up the analog output first. Press ► to scroll through the red Teach LEDs until the AS1 and BS1 LEDs are on, which is for the 0% (4mA) set point. See the chart below for the order and meaning of the red teach LEDs.

	AS1	AS2	BS1	BS2	Speed
QA switchpoint 1	X				
QA switchpoint 2		X			
Invert Output for QA (L.O./D.O.)	X	X			
QB switchpoint 1			X		
QB switchpoint 2				X	
Invert Output for QB (L.O./D.O.)			X	X	
0% (4mA) point for Analog Output	X		X		
100% (20mA) point for Analog Output		X		X	
Speed Mode					X

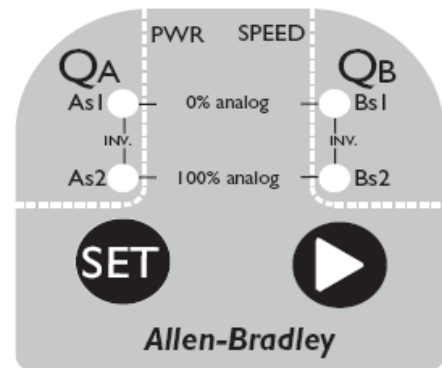

6. If the red LEDs are flashing, the target is not in range or is not reflecting enough light. Move the target into range until the red LEDs stay on.
7. While the AS1 and BS1 LEDs are on, press the SET button for 3 seconds. The red LEDs will blink 3 times to indicate the point has been taught.
8. Move the target to the “far” position. The target should be at least 600mm / 2 feet farther away than the “close” position.
9. Press ► once so that the AS2 and BS2 LEDs are on, which is for the 100% (20mA) set point.
10. Press SET for 3 seconds. The red LEDs will blink 3 times to confirm the teach.

NOTE: The minimum measuring range for the analog output is 600mm (2 feet). If the setpoints are less than 600mm apart, the sensor will automatically scale the analog output (0 to 100%) to 600mm and the midpoint of this will be automatically set at the midpoint between the two original setpoints

11. Press SET and ► simultaneously for 1 second until the red LEDs turn off, indicating that the sensor is in run mode.
12. Move the target between the “close” and “far” positions. Note the output on the multimeter adjusts accordingly.

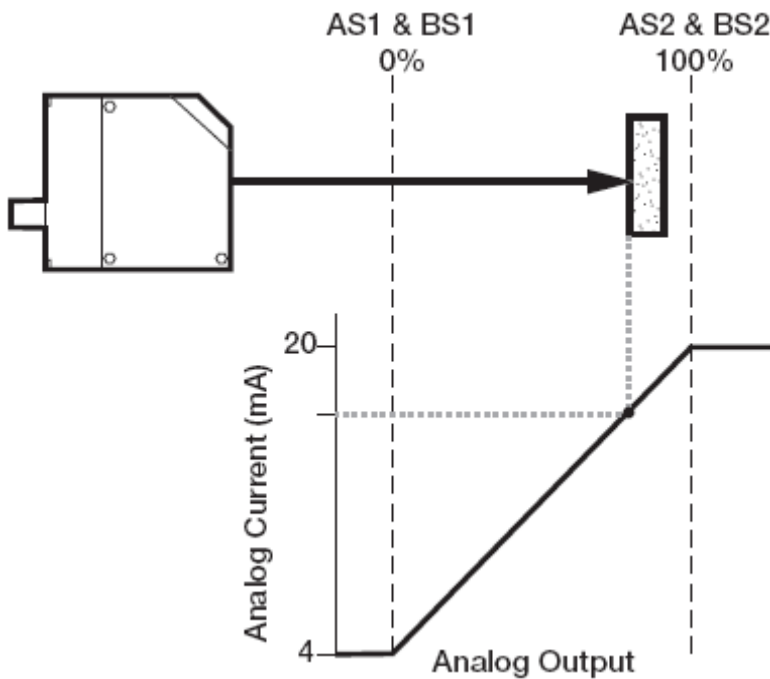

45CPD Teach Process – Discrete Outputs – Background Suppression Applications

In this section of the lab, you will learn how to teach the discrete outputs of the 45CPD sensor for Background Suppression applications.

3. Point the sensor at a wall (or other suitable background) 1 to 6 m (3 to 20 feet) away.

4. Position the target (chair, lab partner, other movable object...) immediately in front of the background.
5. Press SET for 3 seconds to put the sensor in Teach mode. The red AS1 LED will turn on and the laser source will change to visible red, creating a red spot on the target.
6. To teach output 1 (QA), press SET for 3 seconds until the red AS1 LED blinks 3 times to confirm the teach.

NOTE: If you wanted to set up output 2 (QB), you would press ► until the BS1 LED turns on before pressing SET.

7. Press SET and ► simultaneously for 1 second until the red LEDs turn off, indicating that the sensor is in run mode.
8. Remove the target – the output will turn off. Put the target back into position – the output will turn on. (Ignore the other discrete output.)

45CPD Teach Process – Discrete Outputs – Background as a “Reflector”

In this section of the lab, you will learn how to teach the discrete outputs of the 45CPD sensor for “Reflective” mode with the background object as a “reflector.” Use this mode when the target does not reflect enough light for consistent detection in Background Suppression mode. Some example applications might include very dark / non-reflective objects, irregularly shaped objects, or long range targets where there is a fixed object in the background within range (6m) that reflects enough light to be detected, such as a wall, conveyor, or solid fixture. See illustration below.

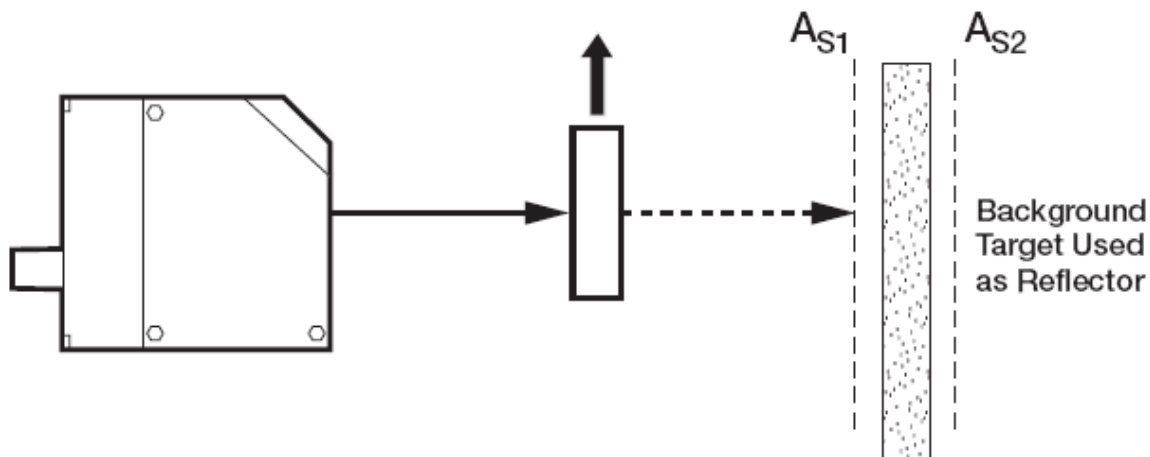

1. Point the sensor at a wall (or other suitable background) 1 to 6 m (3 to 20 feet) away. Leave about 50mm / 2 inches in front and behind the sensor to slide it towards and away from the target during the teach process.
2. Press SET for 3 seconds to put the sensor in Teach mode. The red AS1 LED will turn on and the laser source will change to visible red, creating a red spot on the target.
3. Move the sensor about 50mm / 2 inches closer to the background. Press SET for 3 seconds until the red AS1 LED blinks.

4. Press ► once. The AS2 LED will turn on.
5. Move the sensor about 100mm / 4 inches away from the target (50mm / 2 inches behind the original position).
6. Press SET for 3 seconds until the AS2 LED blinks.
7. Move the sensor to the original position. The output will turn on.
8. Now we want to invert the logic so that the target will turn the output ON and the output will be OFF when it only sees the background.
9. Press ► once. Both the AS1 and AS2 LEDs will turn on. This is also marked “INV” (Invert) on the label.
10. Press SET for 3 seconds until both the AS1 and AS2 LEDs blink. The output will invert (in this case, turn off).
11. Press SET and ► simultaneously for 1 second until the red LEDs turn off, indicating that the sensor is in run mode.
12. Place a target in front of the background – the output will turn on. (Ignore the other discrete output.) Find a dark, non-reflective target and show that this setup works even when the target itself does not reflect enough light to be “seen” by the sensor

45CPD Teach Process – Discrete Outputs – Other Applications

Set up the sensor to use BOTH discrete output, QA and QB. Show that the 2 outputs can be used in very different portions of the sensors range, as in the below illustration.

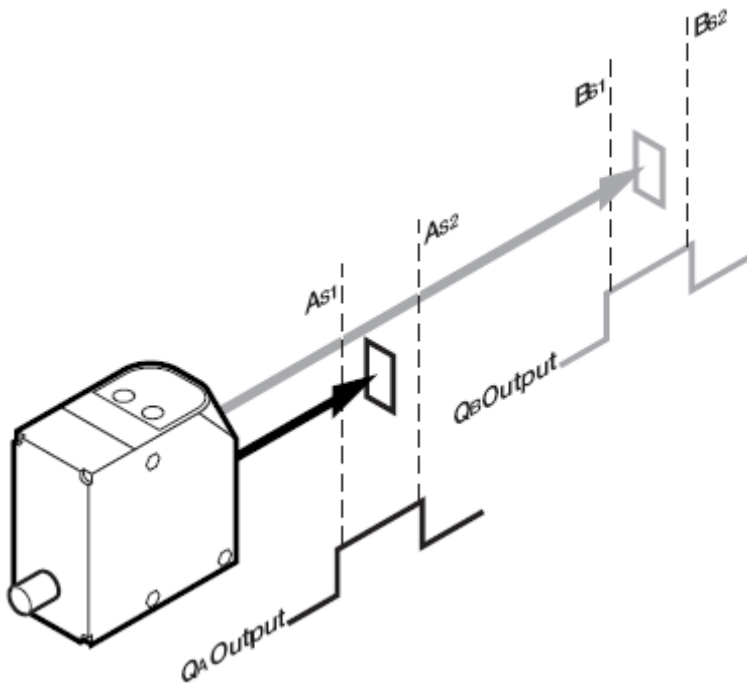

Welcome to Clear Object Detection Hands-On Lab

About This Hands-On Lab

Welcome to the Clear Object Section Hands-On Sensor Lab! This session provides you with an opportunity to explore the challenges of sensing clear objects and learn about the advanced Allen-Bradley sensors designed specifically for these applications. The following sections explain what you'll be doing in this lab session, and what you will need to do to complete the hands-on exercises.

What You Will Accomplish In This Lab

As you complete the exercises in this hands-on session, you will:

- Learn about the challenges of detecting clear objects
- Learn about several sensors appropriate for these applications

Who Should Complete This Lab

This hands-on lab is intended for individuals who:

- Sell sensors
- Specify and/or recommend sensors

Lab Materials

For this Hands-On lab, we have provided you with the following materials that will allow you to complete the labs in this workbook.

Hardware

This hands-on lab uses the following hardware:

- 42KL-U2LB-A2 Standard Retroreflective MiniSight
- 42EF-C2KBA-F4 ClearSight RightSight
- 873EEDZZ0750F4 RightSound Ultrasonic sensor emitter
- 873ERDTT0750F4 RightSound Ultrasonic sensor receiver

Accessories and Targets

This hands-on lab uses the following accessories and targets:

- 24VDC Power Supply
- 2 x 4 conductor Micro QD Cordset – 889D-F4AC-2
- Base, stand, and clamp
- 2 Clear plastic bottles, clear glass bottle

Clear Object Detection – Standard Retroreflective vs. ClearSight

Clear Object Detection is the ability of the sensor to reliably detect clear/ transparent objects (glass or plastic) in typical industrial environments.

The objective of this experiment is to detect the presence of Clear Objects first by using a standard Retroreflective Photoeye, then using a ClearSight RightSight Photoelectric sensor. The ClearSight RightSight Photoeye uses advanced circular polarization optics & smaller hysteresis to achieve its ability to detect clear glass and plastic. Finally detection on clear objects using ultrasonic technology will be examined and experimented. These applications are common in bottling applications where reliable detection of the clear glass or plastic bottle is required to insure accurate process and packaging

1. Use the 42KL-U2LB-F4 MiniSight for the first part of this lab. Connect the sensor to a Micro QD cordset.
2. Connect the Brown wire of the cordset to V+ (24VDC) on the power supply.
3. Connect the Blue wire of the cordset to V- (usually GND) on the power supply.
4. Connect the Black wire of the cordset to the output terminal of the power supply (if available)
5. Turn on the power supply.
6. Place the sensor in the stand and align it to the reflector approximately 8-10 inches away. Make sure that both the green power light and the red margin light are on (Indicator lights are at the rear of the sensor).
7. Pass the different clear objects (glass bottle and the 2 plastic bottles) between the sensor and the reflector. What happens to the output (orange indicator light on the back of the sensor) when the clear objects are passed through the beam?

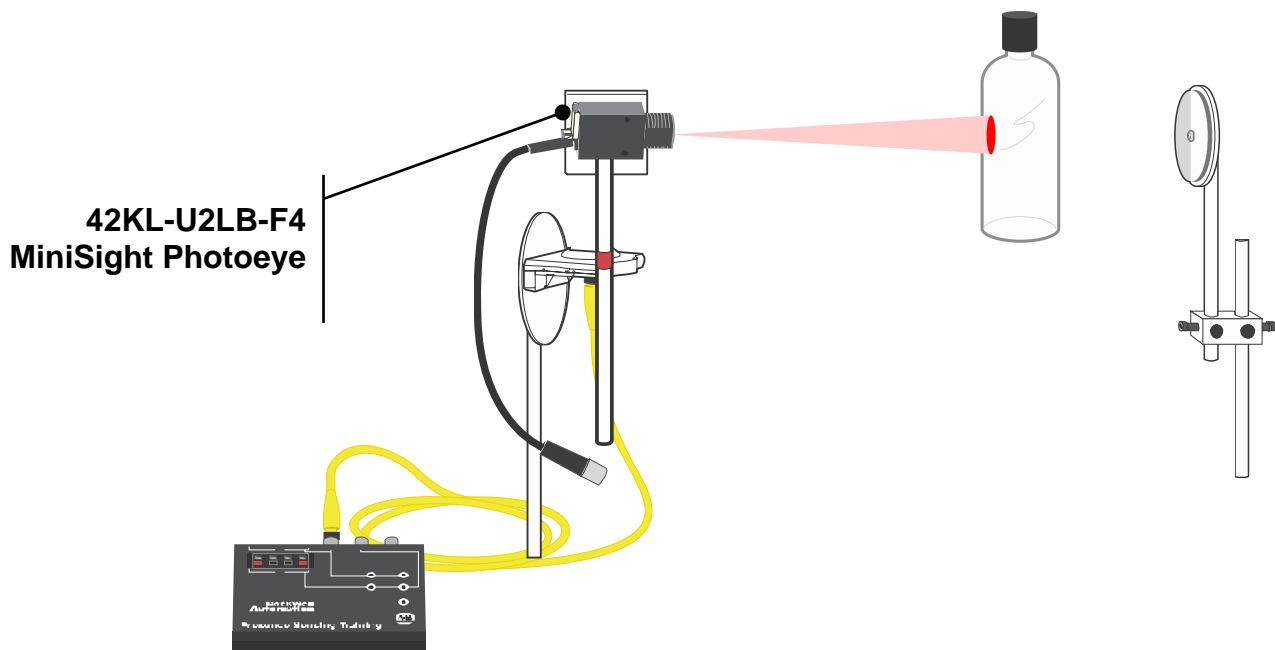

8. Disconnect the MiniSight from the cordset
9. Connect the ClearSight RightSight (42EF-C2KBA-F4) to the cordset
10. Place the sensor in the stand and align it with the reflector, spacing them 8-12 inches apart. Make sure both the red margin light and the green power light are on.
11. Pass the glass bottle between the sensor and the reflector. What happens to the output of the sensor?
12. Pass the plastic water bottle between the sensor and the reflector. If the output of the sensor turns on and off multiple times, the sensitivity of the sensor is too high. Turn down the sensitivity of the sensor by turning the adjustment knob on the top of the sensor counterclockwise. Make sure you still have both the red and green indicator lights on when adjusting the sensitivity.
13. How does the ClearSight compare to the standard Retroreflective MiniSight?

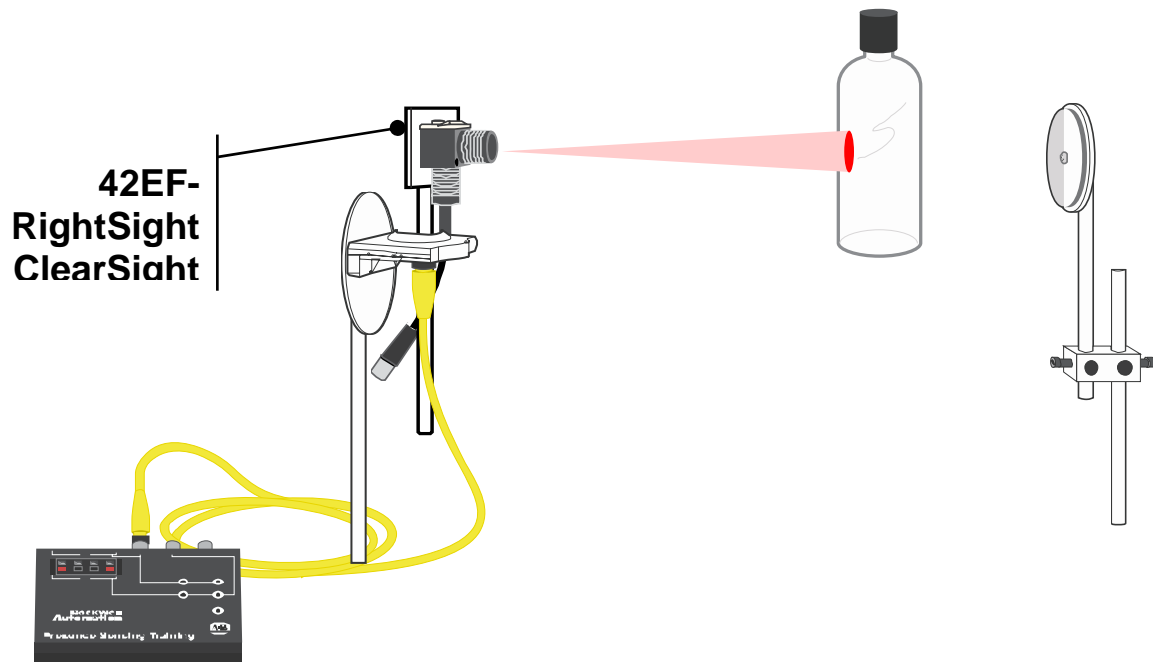

Clear Object Detection – RightSound (873E) Ultrasonic

In this section of the lab, you will learn about clear object detection using the RightSound (873E) ultrasonic sensor.

1. Connect the 873E source (873E-EDZZ0750F4) with the micro QD cordset.
2. Connect the Brown wire of the cordset to V+ (24VDC) and the Blue wire of the cordset to V- (usually GND) on the power supply.
3. Connect the 873E receiver (873E-RDZZ0750F4) with the other micro QD cordset. In order to make the sensor operate in Normally Closed mode, reverse the power connection on the receiver unit's cordset.
 - a. Connect the BLUE wire of the cordset to V+ (24VDC) on the power supply.
 - b. Connect the BROWN wire of the cordset to V- (usually GND) on the power supply.

NOTE: Definition of Normally Closed for Ultrasonic sensor – Think of the receiver as a “sound operated relay”. When the receiver “hears sound” from the emitter, this is the exception state. When it does not “hear” the emitter, this is the Normal state. In the application, if there is no target, the receiver “hears” the emitter – the receiver is in the exception state and therefore a Normally Closed output will be OFF (Open).

4. Connect the Black wire of the cordset to the output terminal of the power supply (if available)
5. Place the source and receiver in the stands and space them 8-12 inches apart. Align the sensors so that only the green LED indicator on the receiver is on. You might have to adjust the volume on the source.
6. Pass the glass and plastic bottles between the two sensors. What happens to the output of the receiver?

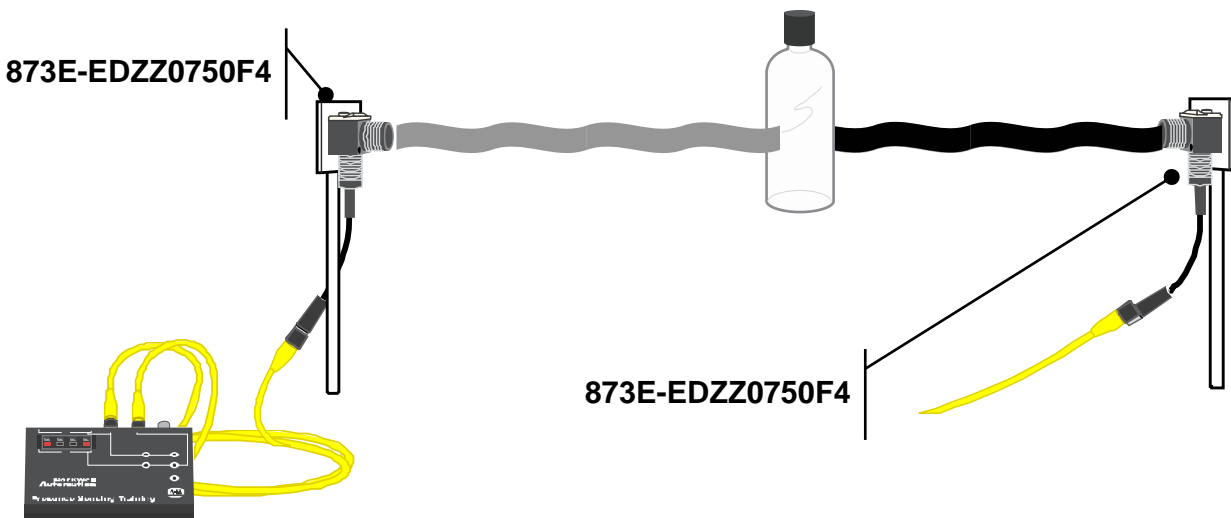

Welcome to ColorSight™ 45CLR Hands-On Lab

About This Hands-On Lab

Welcome to the ColorSight™ 45CLR color sensor Hands-On Lab! This session provides you with an opportunity to explore the functionality of the newest Allen-Bradley color sensor. You will learn both the basic teach functions and more advanced functionality of the sensor. The following sections explain what you'll be doing in this lab session, and what you will need to do to complete the hands-on exercises.

What You Will Accomplish In This Lab

As you complete the exercises in this hands-on session, you will:

- Learn how to teach the new ColorSight™ 45CLR sensor
- Learn about the color scan function of the sensor

Who Should Complete This Lab

This hands-on lab is intended for individuals who:

- Sell sensors
- Specify and/or recommend sensors

Lab Materials

For this Hands-On lab, we have provided you with the following materials that will allow you to complete the labs in this workbook.

Hardware

This hands-on lab uses the following hardware:

- ColorSight™ 45CLR sensor 45CLR-5JPC1-D8

Accessories and Targets

This hands-on lab uses the following accessories and targets:

- 24VDC Power Supply
- 8 conductor Micro QD Cordset – 889D-F8AB-2
- Base, stand, and clamp
- Paint color cards – 3 similar colors and at least 1 very different color

Basic ColorSight™ 45CLR sensor setup

In this section of the lab, you will set up the ColorSight™ 45CLR sensor.

1. Connect the cordset to the sensor.
2. Mount the sensor pointing down at the table at a range of 25 to 30mm (just over an inch). Position the Teach buttons facing out towards yourself. Full range of the sensor is 12...32 mm, with a tolerance of +/- 6 mm.
3. Position the sensor at 10 to 30 degrees from perpendicular.

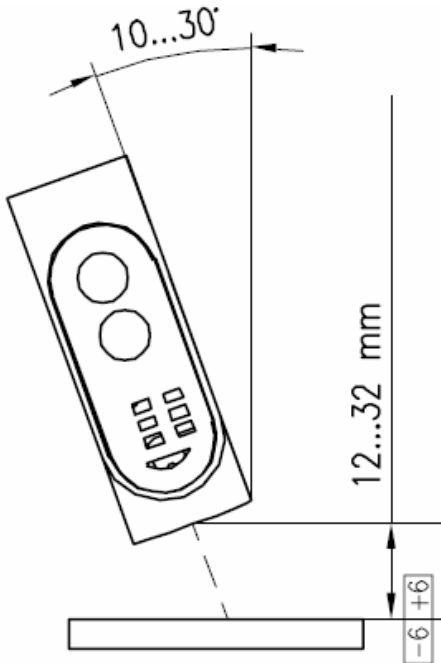

4. Connect the Brown wire of the cordset to V+ (24VDC) on the power supply.
5. Connect the Blue wire of the cordset to V- (usually GND) on the power supply.
6. Connect the Green wire of the cordset to the output terminal of the power supply (if available)

Pin	Color	Connection
1	White	Gate input
2	Brown	V+ 12-28 VDC
3	Green	OUT 1
4	Yellow	OUT 2 / Teach Confirmation
5	Gray	Teach Button Lock
6	Pink	OUT 3 / Remote Teach
7	Blue	V- 0 VDC
8	Red	Not Connected

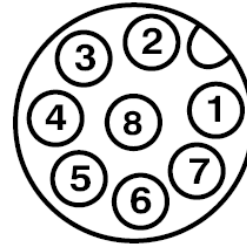

7. Familiarize yourself with the push buttons and indicator LEDs

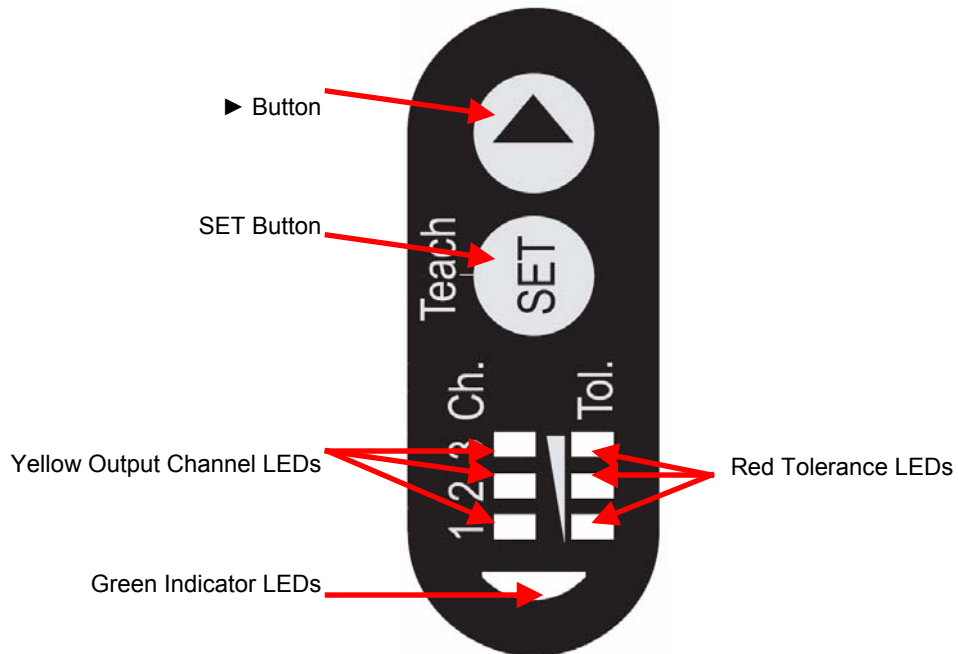

Teaching the ColorSight™ 45CLR sensor

In this section of the lab, you will learn how to perform a basic teach the color sensor.

1. Turn the power supply on.
2. You will see a white light spot from the sensor on the table.
3. Place a color card under the sensor. Position the card so that the white spot is completely on the card.
4. Reset the sensor to the factory default state with the following steps:
 - c. Put the sensor in Teach mode by pressing SET for 3 seconds until the green LED turns off and the Ch 1 yellow LED turns on. The white light spot will turn off.
 - d. Press the ► button multiple times until all three yellow channel LEDs turn on.
 - e. Press SET for 3 seconds until the first red Tol. (Tolerance) LED turns on.
 - f. Press ► multiple times until both of the first two Tol. LEDs turn on
 - g. Press SET for 1 second until the green LED turns on.
 - h. Press ► once – both red Tol. LEDs turn off.
 - i. Press SET for 3 seconds until the green LED turns on and the white light spot turns on.
5. Press SET for 3 seconds until the green LED turns off and the Ch 1 yellow LED turns on.
6. Select Channel 1 by pressing SET for 3 seconds until the middle red Tol. LED turns on.
7. Select Medium Tolerance by pressing SET for 3 seconds until the green LED and white light spot turn on.
8. Confirm the sensor output operates for the taught color. Place the color card so that the white spot is entirely on the card. The yellow Ch. 1 LED turns on.
9. Place the other color cards under the sensor. Do any other colors turn the output on? The matched colors can be adjusted by changing the tolerance setting in teach mode.

Using the Color Scan function of the ColorSight™ 45CLR sensor

In this section of the lab, you will learn how to use the Color Scan function of the color sensor. This function of the sensor allows a single output channel to be taught multiple colors. This is very useful in applications where you need to match two or three (or more) specific colors or where a very wide tolerance of a single basic color needs to be matched.

1. Place a color card under the sensor. Position the card so that the white spot is completely on the card. Place a different color card immediately next to the first card

2. Press SET for 3 seconds until the green LED turns off and the Ch 1 yellow LED turns on.
3. Select Channel 1 by pressing SET for 3 seconds until the middle red Tol. LED turns on.
4. Enable the color scan – press SET, hold for 10 seconds until the green LED flashes continue holding the SET button while sliding the second color card under the white spot. All colors that the sensor sees while the SET button is pressed will be stored. Release the button when you have completed scanning colors. The sensor is now in run mode
5. Confirm that each scanned color turns the Channel 1 output (and yellow LED) on.

Advanced ColorSight™ 45CLR sensor functions: Teach multiple channels and change tolerance settings

In this section of the lab, you will learn how to teach multiple output channels of the color sensor. use the Color Scan function of the color sensor. You will also adjust the tolerance settings and observe how it affects the sensor's performance.





1. Place a color card under the sensor. Position the card so that the white spot is completely on the card.
2. Press ► once – the Ch 2 yellow LED turns on.
3. Select Channel 2 by pressing SET for 3 seconds until the middle red Tol. LED turns on.
4. Press ► multiple times until smallest Tol. (Tolerance) LED is on.
5. Press SET for 3 seconds until the green LED and white light spot turn on.
6. Observe the behavior of output channel 2 as you place multiple similar color cards under the sensor. Does the output turn on for any color variations?
7. Take the original color card and slide it into the field of view slightly above the table. Does output channel 2 turn on? Try again a little higher. How much distance tolerance does the sensor have at this tightest tolerance setting?
8. Put the color card back on the table in the field of view (white spot entirely on the card).
9. Press SET for 3 seconds until the green LED turns off and the Ch 1 yellow LED turns on.
10. Press ► twice – the Ch 3 yellow LED turns on.
11. Select Channel 3 by pressing SET for 3 seconds until the middle red Tol. LED turns on.
12. Press ► twice so that only the highest Tol. LED is on.
13. Press SET for 3 seconds until the green LED and white light spot turn on.
14. Observe the behavior of output channel 3 as you place multiple similar color cards under the sensor. Does the output turn on for any color variations?
15. Compare the performance of output channel 2 to output channel 3. How does the tolerance setting affect the performance of the sensor?

Advanced ColorSight™ 45CLR sensor functions: Remote Teach

In this section of the lab, you will learn how to use the remote teach function of the color sensor.

1. Place a different color card under the sensor. Position the card so that the white spot is completely on the card.
2. Put the sensor in remote teach mode with the following steps:
 - a. Put the sensor in Teach mode by pressing SET for 3 seconds until the green LED turns off and the Ch 1 yellow LED turns on. The white light spot will turn off.
 - b. Press the ► button multiple times until all three yellow channel LEDs turn on.
 - c. Press SET for 3 seconds until the first red Tol. (Tolerance) LED turns on.
 - d. Press ► once – the middle red Tol. LED will turn on.
 - e. Press SET for 1 second until the green LED turns on.
 - f. Press ► twice – both red Tol. LEDs turn off.
 - g. Press SET for 3 seconds until the green LED turns on and the white light spot turns on. The sensor is operational and remote teach is enabled.

NOTE: The chart below shows the meaning of the red Tol. Indicators when in the special functions mode. If the green LED is on, that function is enabled. If the green LED is off, that function is off. To change the setting of a function, press SET for one second until the green LED changes state.

Tol. Display	Function
	Pulse stretcher – 50 ms
	Remote Teach
	RESET to default
	Menu exit

3. Briefly touch the Pink cordset wire to V+ / 24VDC. The white light spot will blank and the new color is taught on output channel 1.
4. Note that when you touch the Pink wire to V+, the yellow output channel 2 LED briefly flashes. When the sensor is in remote teach mode, output channel 2 provides a 50ms output pulse to confirm that the color was taught. This can be used to provide feedback to the control system.

5. Turn the remote teach function off with the following steps:
 - a. Put the sensor in Teach mode by pressing SET for 3 seconds until the green LED turns off and the Ch 1 yellow LED turns on. The white light spot will turn off.
 - b. Press the ► button multiple times until all three yellow channel LEDs turn on.
 - c. Press SET for 3 seconds until the first red Tol. (Tolerance) LED turns on.
 - d. Press ► once – the middle red Tol. LED and green LED will turn on.
 - e. Press SET for 1 second until the green LED turns off.
 - f. Press ► twice – both red Tol. LEDs turn off.
 - g. Press SET for 3 seconds until the green LED turns on and the white light spot turns on. The sensor is operational and remote teach is turned off.